

Nice

Clima-Control

Universal Z-Wave to IR A/C Thermostat

EN - Instructions and warnings for installation and use

1 WARNINGS AND GENERAL PRECAUTIONS

- **CAUTION!** – Read the instructions before starting up the unit!
- **CAUTION!** – This product is not a toy. Keep out of reach of children and animals!
- **CAUTION!** – Do not expose the device to moisture, water or other liquids. Do not place liquids near or on the device!
- **CAUTION!** – Do not attempt to disassemble, repair or modify the device yourself!
- **CAUTION!** – This product is for indoor use only. Do not use outdoors!

2 PRODUCT SPECIFICATION

Clima-Control is a Z-Wave 800 series thermostat that is a Z-Wave-to-IR converter for controlling air conditioners by receiving Z-Wave commands and converting them to IR commands. Clima-Control can control different makes and models of air conditioners thanks to a large database of IR codes stored in the cloud. The clear and large display allows the temperature and humidity to be intuitively read and the air conditioner to be easily controlled with buttons.

Table A1 - Specifications	
Power Supply	Rechargeable battery/ 5V USB Type-C
Z-Wave series	800
Encryption support	S2 encryption
Temperature Range	0~55°C (32-131F)
Humidity Range	0%~90%RH
Working Environment	-10~+55°C <90%RH (Non-condensation)
Dimension	105*105*15.6 mm
Z-Wave Frequency	Operating frequency range, defined by the regulatory bodies (for Z-wave in Europe: 868.4 MHz, or other regions 908.4/916.0 MHz , 921.4 MHz)
Maximum Transmitting Power	+3dBm
Housing	PC+ABS
Installation	Wall-mounted (with screws or supplied double-sided tape) or tabletop placing



3 INSTALLATION

- **CAUTION!** – Cut off power supply at circuit breaker or fuse before installation to avoid fire, shock or death!

Note:

The device is a wall-mounted unit with screws or supplied double-sided tape.

- 3.1** - Separate the device into two parts: the front panel and the mounting plate.

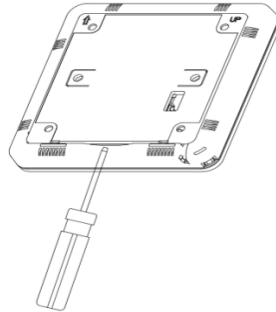

- 3.2** - Put 5V adapter (not included) into the flush-mounted box, Insert the wire into the 5V terminal by following the wiring diagram as below depending of location (wall-mounted or flush-mounted installation)

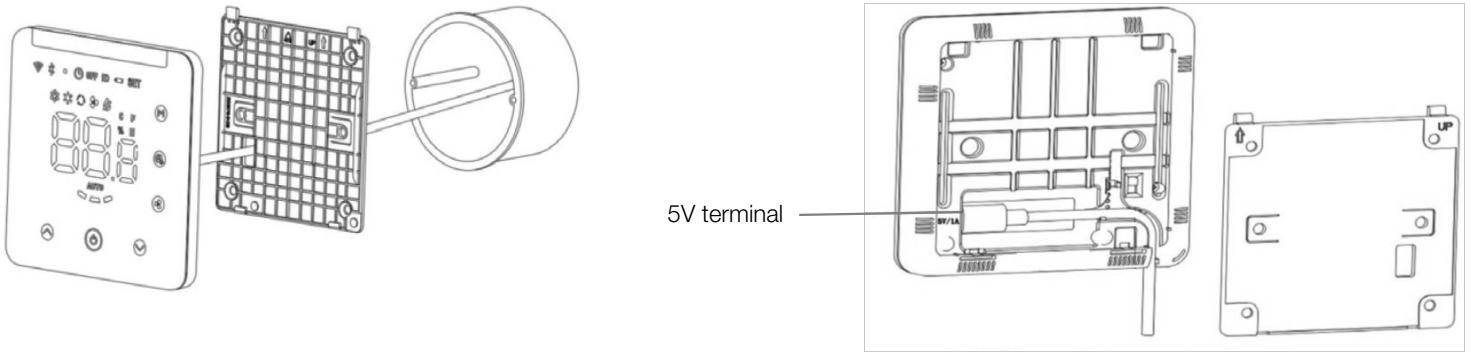

- 3.3** - Fix the mounting plate to flush-mounted box with the screw or use double-sided tape as indicated below.

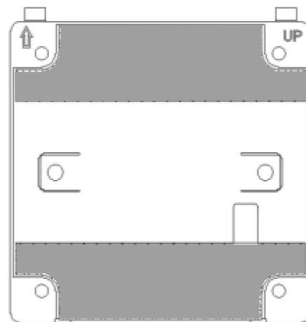

Double-stick tape mounting: position for the double-stick tape.

- 3.4** - Confirm the device is well mounted and then power it on.

4 BUTTONS AND DISPLAY

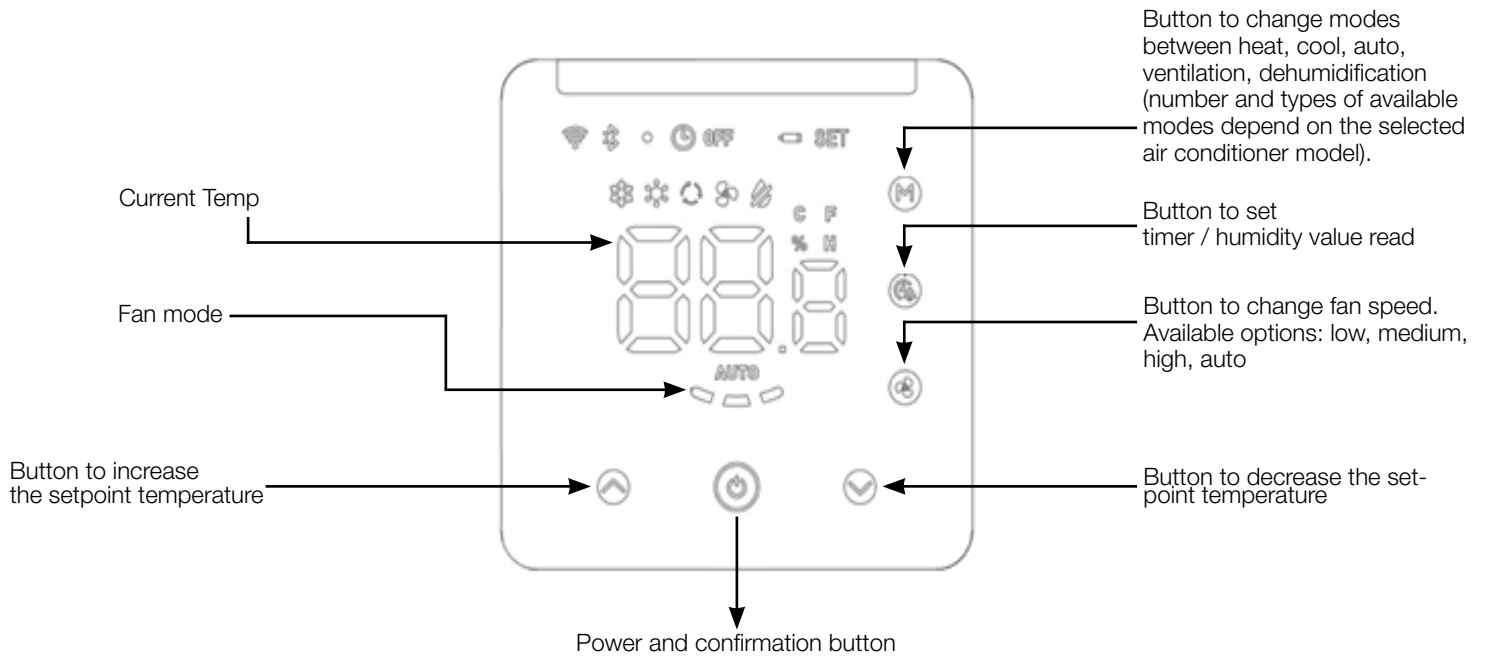

1. Hub connection indicator - provide information if Clima-Control is connected to Yubii Home
2. Bluetooth on/off indicator - it is necessary to be enabled during setup of make and model of air conditioner
3. Diode indicator power status of the device:
 - Green - device fully recharged (available when back switch turned on)
 - Red - device is recharging the battery (available when back switch turned off)
 - no indicator - battery recharging function is switched off by back switch on/off
4. Timer Indicator
5. **OFF** Indicates that device is not controlling A/C
6. **ID** Z-Wave ID
7. Low Battery-Power Warning
8. **SET** indicates changing settings of A/C

5 POWER SUPPLY MODE

5.1 - On/Off Setting

In battery charge mode: remove the mounting plate at the back, switch the power button ON, then the device will be powered by inbuilt rechargeable battery. In this mode the battery will be recharged when 5V USB Type-C plug is plugged in and power is supplied. Note: If the rechargeable battery has run out of the power, please charge the device by 5V USB Type-C. This mode is not recommended if power will always be supplied by 5V USB Type-C plug.

5.2 - In 5V USB Type-C power supply mode: remove the mounting plate at the back, put the charging wire into 5V USB Type-C charging port and switch the power button OFF. In this mode the rechargeable battery will not be charged. Device will be directly powered by power supply.

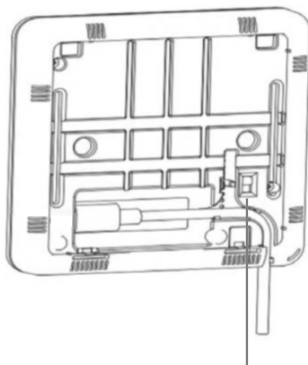

On/Off button for battery charging mode

6 AIR CONDITIONING SETTINGS

This sections describes ho to properly setup the device in order to work wit Air conditioner.

6.1 - Download the IR library app.

- In order to set the make and model of the air conditioner once and to upload the correct IR codes to the unit, download the IR thermostat app. It will be used once and can later be deleted from your phone. Application is available here:

Android: <https://play.google.com/store/apps/details?id=com.mcohome.codingctrl&hl=pl&gl=US>

iOS: <https://apps.apple.com/uz/app/ir-thermostat/id1582146430>



6.2 - Connect mobile to Clima-Control

When there is no infrared code library in the device (the device has not been uploaded with the infrared code or the device has been restored into default factory settings), the device automatically enters the bluetooth pairing mode when powered by USB. The bluetooth is flashing and the ID number of bluetooth is displayed on the device screen. Note that you can tap any key to exit the bluetooth pairing mode or it will automatically exit the bluetooth paring mode after 30 minutes.

To enable again bluetooth paring mode long press **M** + **⌂** key of the device synchronously for 3sec until the Bluetooth icon in the upper left corner flashes. Click "Next" in the app and app will scan bluetooth device. "Clima-Control_X123" will appear on the APP. Then click to complete the connection. The Bluetooth icon of Clima-Control will light up solid after successful connection.

6.3 - Choose a brand and model of air conditioner



Enter air conditioner brand name in search area or manually find the corresponding brand then click to enter the next step.

Place the device in front of the air conditioner as close as possible (within 7 meters). If the air conditioner can be correctly controlled by testing more than three different keys on the app interface, the pairing will be considered successful. If it is not working, click "Next" at the bottom right corner and repeat the test until a successful pair. If it is successful click downlad button and start process of transferring IR button codes into the device. After the process succeeds close the application and go to the next step.

7 ADDING / REMOVING CLIMA-CONTROL FROM Z-WAVE NETWORK

7.1 - Adding device using the manual method

To add the device to the Z-Wave network manually:



1. Set the Yubii Home into add mode (see the Yubii Home manual).
2. In the home page, long press  +  synchronously for 3 sec, Clima-Control enters into adding mode displaying product ID on the interface. Please note It should be displayed 000. In case there is another number displayed please follow the procedure of removing the device from the network first (described below) or restore the device to factory defaults.
3. Press  to include the device into Z-Wave network, if the inclusion is successful, it will not show 000 on the interface anymore.

7.2 - Adding device using the SmartStart method

To add Clima-Control to the Z-Wave network using SmartStart:

1. Scan the DSK QR code or input the underlined 5-digit PIN code (label on the side of the box and on the device).
2. Power the device (turn on the mains voltage).
3. Successful adding will be confirmed by the Z-Wave indicator on the display

7.3 - Removing device from Yubii Home

1. In the home page, long press  +  synchronously for 3 sec, Clima-Control enters into adding mode displaying product ID on the interface. Please note that if a device has been added to the gateway It should be displaying number different from 000.
2. Press  to exclude the device from Z-Wave network, if the exclusion is successful, it will show 000 in the interface.

8 PROBLEMS THAT YOU MAY ENCOUNTER

8.1 - Some keys are not being able to control the air conditioner.

There is a chance, that a inappropriate infrared code was chosen, please follow the above steps on the APP to choose the most matching set of infrared code.

Note:

This may occur if the device supports less functionality than is provided for in the device (e.g. modes of operation).

8.2 - I can't find the model of my air conditioner

This can happen if there is no device-specific code in the code base of the application. Please contact us by sending the specific type and model of air conditioning unit.

8.3 - Tried everything but couldn't control the air conditioner

Please take a picture of the model of the remote control and send it back to the manufacturer.

9.1 - Room A/C thermostat controller (default)

This is default mode of operation where there is A/C unit assigned and controlled through the device.

Scheduling should be set-up by including this device in climate zone and adjusting temperatures and change times in the zone.

Any changes of the temperature on the Clima-Control interface when devices is part of the zone will override the scheduled setpoint for 2 hours.

Note:

Clima-Control is one-way controller and is not able to intercept any commands sent to A/C by a remote controller supplied with air conditioner or i.e wifi connection. Therefore any changes made aside from Clima-Control will not be reflected in settings displayed on the screen.

9.2 - Zone temperature controller

In this mode Clima-Control can control whole zone and devices that are included in it.

Setting the setpoint will be reflected on each device in the zone. In order to use this mode please add new device (Add device >> Other Device >> thermostat & Heating Zone).

In advanced section of the added device user can choose - time of manual setpoint override, choose Clima-control as controlling thermostat and controlled Heating zone. Please note that in this mode it is not necessary to set up IR codes described in section 7.

9.3 - Heating Boiler thermostat

This mode can work simultaneously with any of 2 modes described above.

In this mode Clima-Control can work directly with Nice SingleSmart-Control or DoubleSmart-Control that control energy source that uses 2 wires dry contact or Nice SingleSwitch-Control and Switch-Control in case of load control.

The connection between Clima-Control and Nice switch is made using association which is described below.

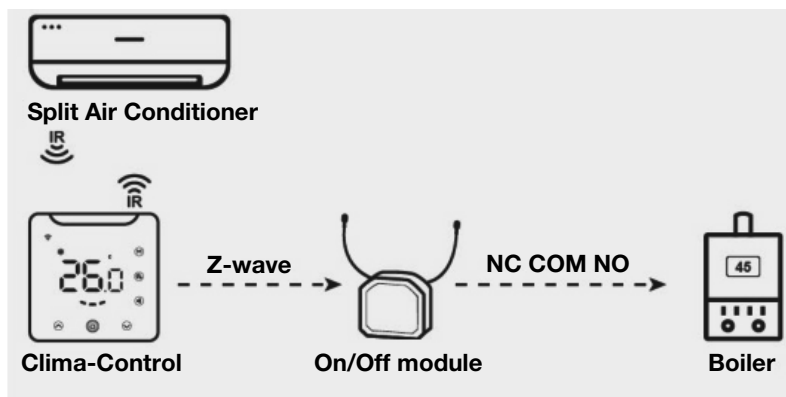

10 OPERATION - BATCH DOWNLOAD INFRARED CODE LIBRARY

10.1 - If the device has downloaded the infrared code, then restore the device into factory setting first.



10.2 - Power on multiple device (Clima-Control) within 5 meters from the mobile phone (as the Bluetooth pairing mode will automatically exit after 30 minutes if the device is powered by battery, we suggest that there is no more than 280 units of devices to be download the infrared code library in batch at a time when the devices are powered by battery, otherwise some devices may not be downloaded successfully. But there is no limit if the devices are powered by USB). All devices (Clima-Control) enter the Bluetooth pairing mode, and the ID number of Bluetooth will be displayed on the screens.

10.3 - Open the "IR thermostat" APP, click the Batch Download, check the infrared code to be downloaded, and then click Start Batch Download. The mobile APP will automatically connect the devices (Clima-Control) and download the infrared code one by one. Keep the devices powered on and do not manually operate the devices until the download is completed. After infrared codes are download completely, the device Bluetooth indicator will automatically turn off. If the device is powered by battery, it will enter the sleep mode automatically. If the device is powered by USB, it will automatically enter the Home page and after a period of time to transfer to sleep mode.

11 OPERATION - DEVICE FUNCTIONS

11.1 - Temperature Setting

Indoor temperature is displayed on the home page.

Setting temperature of current mode is displayed on the interface when pressing  or , "SET" icon will be displayed on upper right side, the setting temperature value is adjustable.

11.2 - Battery Level Display





In the home page, long press  for 3 sec, "xx.x% (x indicates digit)" will be displayed on the interface, it is the percentage value of the remaining capacity of the battery, then press any key to exit.

11.3 - Humidity Value Display

In the home page, long press  for 3 sec, "xx.x% (x indicates digit)" will be displayed on the interface, it is the percentage value of the remaining capacity of the battery, then press any key to exit.

11.4 - Timer Function







Set timer to turn off the air conditioner regularly

1. In the home page, short press  to enter the timer setting interface, the timer indicator icon will flash constantly.
2. Short press  or  to set the timer of turning off the air conditioner regularly (setting range is 0.5-24H), after the timer is set, short press  again to enable the timer shutdown function, then timer indicator icon will be always on.

Disable timer function.

In the home page, short press  twice to disable the timer function, the timer indicator icon will be disappeared.

11.5 - Temperature Deadband Setting (when the device is controlled by IR)

Long press  +  +  synchronously for 3 sec, it displays current value of deadband, short press  or  to adjust the value then press  to confirm and exit.

Note

When deadband is 0 (default value), the control logic of the device is the same as the AC remote control, that means the setting temperature on the device is the same as the AC.

When deadband is set to 1-3, the device will follow thermostat's internal control logic to control AC's setting temperature, in order that the indoor temperature reaches the setting temperature of the device. Note: In this mode, it is normal that the setting temperature of the device differs from that of air conditioner, if you want to keep the indoor temperature value close to the setting temperature of the device, set deadband to 1.)

12 ASSOCIATION

The devices working in On/Off mode can be directly connected to Clima-Control (i.e Boilers, electrical heaters).

It is possible able to associate with at most 5 pieces of Z-Wave on/off modules, the heating equipment can be replaced by a cooling equipment or a fan or other devices working in on/off modes.

Please note that direct connection between Clima-Control and other devices can be established only between devices with same security level. No intermediary nodes are allowed either which means that both devices need to be in direct radio range.

Table A2 - Association group			
AG Identifier	Max Node ID	Command Class	Trigger Situation
1	1	COMMAND_CLASS_SENSOR_MULTILEVEL_V5, SENSOR_MULTILEVEL_REPORT_V5	1. When temperature unit is Celsius degree, the parameter 2 set to 1, variation of detected temperature is greater than the setting value of parameter 3. 2. The parameter 2 set to 2, when the report is that the interval time is greater than the setting value of parameter 5. 3. When temperature unit is Celsius degree, the parameter 2 set to 3, variation of detected temperature is greater than the setting value of parameter 3 or the reported time is greater than the setting value of parameter 5.
		COMMAND_CLASS_THERMOSTAT_MODE_V2, THERMOSTAT_MODE_REPORT	Device mode changes
		COMMAND_CLASS_THERMOSTAT_OPERATING_STATE, THERMOSTAT_OPERATING_STATE_REPORT	Device status changes
		COMMAND_CLASS_THERMOSTAT_SETPOINT_V2, THERMOSTAT_SETPOINT_REPORT_V2	Set point value changes
		COMMAND_CLASS_THERMOSTAT_FAN_MODE, THERMOSTAT_FAN_MODE_REPORT	Fan mode changes
		COMMAND_CLASS_THERMOSTAT_FAN_STATE, THERMOSTAT_FAN_STATE_REPORT	Fan status changes
		COMMAND - CLASS_BATTERY, BATTERY_REPORT	Variation of battery capacity is greater than 5%
2	5	COMMAND_CLASS_BASIC, BASIC_SET	Variation of working status of the device in the heating mode
2	5	COMMAND_CLASS_BASIC, BASIC_SET	Variation of working status of the device in the cooling mode
		COMMAND CLASS_DEVICE_RESET_LOCALLY, DEVICE_RESET_LOCALLY_NOTIFICATION	Restore the factory setting

Table A3 - Advanced parameters			
Parameter:	2. Temp. Difference Reporting		
Description:	Automatically report the temp. to the gateway when temp. variation is greater than this value. Unit: 0.1°C 0: Disabled 3-255: n*0.1 °C		
Available settings:	0, 3-255		
Default setting:	5	Parameter size:	2 [byte]
Parameter:	3. Humidity Difference Reporting		
Description:	Automatically report the humidity to the gateway when humidity variation is greater than this value. 0: Disabled 1-99: automatically report		
Available settings:	0-99		
Default setting:	6	Parameter size:	1 [byte]
Parameter:	4. IR Command Feature In Heat Mode		
Description:	Whether to send IR command or not when the device is in heating mode. 0: Not send 1:Send		
Available settings:	0-1		
Default setting:	1	Parameter size:	1 [byte]
Parameter:	5. IR Command Feature In Cool Mode		
Description:	Whether to send IR command or not when the device is in cooling mode 0: Not send 1:Send		
Available settings:	0-1		
Default setting:	1	Parameter size:	1 [byte]
Parameter:	6. Number Of Resending Command In AG2		
Description:	Number of resending attempts to send a command to the device in associated group 2. 0: Disabled 1-10: The number of times to resend		
Available settings:	0-10		
Default setting:	1	Parameter size:	1 [byte]
Parameter:	7. Number Of Resending Command In AG3		
Description:	Number of resending attempts to send a command to the device in associated group 3. 0: Disabled 1-10: The number of times to resend		
Available settings:	0-10		
Default setting:	1	Parameter size:	1 [byte]
Parameter:	10. Panel Lock		
Description:	Lock and unlock buttons. 0: All buttons are valid. 1: Temp. "Up" & "Down" and "Mode" & "time" button invalid, other buttons valid. 2: Power button valid, other buttons invalid. 3: All buttons are invalid.		
Available settings:	0-3		
Default setting:	0	Parameter size:	1 [byte]

Parameter:	11. Beep Set		
Description:	Set sound signal on/off. 0: Off 1: On		
Available settings:	0-1		
Default setting:	1	Parameter size:	1 [byte]

Parameter:	12. Temp. Hysteresis Using IR For Control		
Description:	Temp. hysteresis (Unit °C). 0: Remote control mode: the setpoint on Clima-Control is the same as Air Conditioner 1-3: Thermostat control mode: the setpoint on Clima-Control is NOT the same as Air Conditioner, there is temp. hysteresis and the setting range is 1-3°C		
Available settings:	0-3		
Default setting:	0	Parameter size:	1 [byte]

Parameter:	13. Temp. Offset		
Description:	Accuracy 0.1 (n*0.1) °C.		
Available settings:	-100~+100		
Default setting:	0	Parameter size:	1 [byte]

Parameter:	14. Screen OFF		
Description:	Automatic screen off time, When the device is charged by USB port: 0: The screen will not turn off automatically; Set 1-90mins to automate turn off the Screen When the device is powered by battery: Set 3-90secs to automate turn off the screen; 0-2: After 8sec the screen will be turned off automatically.		
Available settings:	0-90		
Default setting:	1	Parameter size:	1 [byte]

Parameter:	15. Backlight Brightness		
Description:	Set backlight brightness intensity. 1-8: 8 level backlight brightness 1 is the dimmest, 8 is the brightest		
Available settings:	1-8		
Default setting:	8	Parameter size:	1 [byte]

Parameter:	16. Temp. Hysteresis Using AG For Control		
Description:	Temp. hysteresis when using association group for controlling. n*0.1°C (Unit °C)		
Available settings:	5-30		
Default setting:	10	Parameter size:	1 [byte]

Parameter:	17. Support Cooling Mode		
Description:	Support Cooling Mode. 0: Not support 1: Support (when Air Conditioner does not have cooling mode, set this parameter after the device download the IR code from the library)		
Available settings:	0-1		
Default setting:	1	Parameter size:	1 [byte]

Parameter:	18. Support Heating Mode		
Description:	Support Heating Mode. 0: Not support 1: Support (when Air Conditioner does not have heating mode, set this parameter after the device download the IR code from the library)		
Available settings:	0-1		
Default setting:	1	Parameter size:	1 [byte]

Parameter:	19. Temp. Upper Limit Setting In Cooling Mode		
Description:	Set temperature upper limit in Cooling Mode.		
Available settings:	1-99, n*1°C (Set this parameter after the device download the IR code from the library)		
Default setting:	37	Parameter size:	1 [byte]

Parameter:	20. Temp. Lower Limit Setting In Cooling Mode		
Description:	Set temperature lower limit in Cooling Mode.		
Available settings:	0-98, n*1°C (Set this parameter after the device download the IR code from the library)		
Default setting:	5	Parameter size:	1 [byte]

Parameter:	21. Temp. Upper Limit Setting In Heating Mode		
Description:	Set temperature upper limit in Heating Mode.		
Available settings:	1-99, n*1°C (Set this parameter after the device download the IR code from the library)		
Default setting:	37	Parameter size:	1 [byte]

Parameter:	22. Temp. Lower Limit Setting In Heating Mode		
Description:	Temp. Lower Limit Setting In Heating Mode.		
Available settings:	0-98, n*1°C (Set this parameter after the device download the IR code from the library)		
Default setting:	5	Parameter size:	1 [byte]

Parameter:	23. Local Temp. Setpoint Step Set In Cool Mode		
Description:	If there is ID in AG3, then this parameter will be set to 1 automatically, if not, then this parameter will be set to 0 automatically.		
Available settings:	1: 0.5°C 0: 1°C		
Default setting:	0	Parameter size:	1 [byte]

Parameter:	24. Local Temp. Setpoint Step Set In Heat Mode		
Description:	If there is ID in AG2, then this parameter will be set to 1 automatically, if not, then this parameter will be set to 0 automatically.		
Available settings:	1: 0.5°C 0: 1°C		
Default setting:	0	Parameter size:	1 [byte]

Parameter:	FF. Factory Restore		
Description:	Restore to factory default settings		
Available settings:	1: Restore factory setting 0: invalid		
Default setting:	0	Parameter size:	1 [byte]

14 WARRANTY

We warrant this product to be free from defects in material and workmanship under normal and proper use for one year from purchase date of the original purchaser. We will, at its option, either repair or replace any part of its products that prove defective by reason of improper workmanship or materials. THIS LIMITED WARRANTY DOES NOT COVER ANY DAMAGE TO THIS PRODUCT THAT RESULTS FROM IMPROPER INSTALLATION, ACCIDENT, ABUSE, MISUSE, NATURAL DISASTER, INSUFFICIENT OR EXCESSIVE ELECTRICAL SUPPLY, ABNORMAL MECHANICAL OR ENVIRONMENTAL CONDITIONS, OR ANY UNAUTHORIZED DISASSEMBLY, REPAIR OR MODIFICATION. This limited warranty shall not apply if: (i) the product was not used in accordance with any accompanying instructions, or (ii) the product was not used for its intended function. This limited warranty also does not apply to any product on which the original identification information has been altered, obliterated or removed, that has not been handled or packaged correctly, that has been sold as second-hand or that has been resold contrary to Country and other applicable export regulations.

15 PRODUCT DISPOSAL



The device marked with this symbol should not be disposed of with household waste. It is the user's responsibility to deliver the used appliance to a designated recycling point.

16 DECLARATION OF CONFORMITY



Hereby, NICE S.p.A., declares that the radio equipment Clima-Control sensor is in compliance with Directive 2014/53/EU.

The full text of the EU declaration of conformity is available at the following internet address:
<http://www.niceforyou.com/en/supports> under the "support" and "download" sections.

17 Z-WAVE COMPLIANCE



The thermostat is a fully compatible Z-Wave Plus V2 device.

