

## Datasheet

### V5SR - Surface monitored magnetic lock, LED

#### Product Description

The V5 Series are surface maglocks with a holding force of up to 500kg. They are part of an extensive range of electro-magnetic locks manufactured by CDVI, offering high quality and high performance locking with exceptional features to enhance your installation.

The magnets are delivered with security “catch” ropes to prevent the magnetic lock from falling, preventing the risk of injury when side mounting.

A door positioning monitor ([DPM-500](#)) is available for a more secure system.

**PATENTED  
BREVETÉ**



#### Key Features

- Internal surface electro-magnetic lock
- Up to 500kg holding force
- Live status monitoring
- Patented locking technology
- Monitored version ([V5SR](#)), Audible feedback version ([V5SR-B](#))
- Visual indication with LEDs

 **Blue**  
Active Voltage

 **Green**  
Open

 Certification

 DEEE

**RoHS** Certification

 IP42

 EN1634-1/2 (30 min)

 -25°C to 70°C



## Product Specifications

<b>Mounting:</b>	Surface
<b>Lock mode:</b>	Fail safe
<b>Holding force:</b>	500kg
<b>Contacts:</b>	NO/NC
<b>Relays:</b>	1
<b>Weight:</b>	2.86kg
<b>Dimensions:</b>	
• Maglock:	266 x 66 x 40 mm
• Armature plate:	185 x 60 x 12 mm

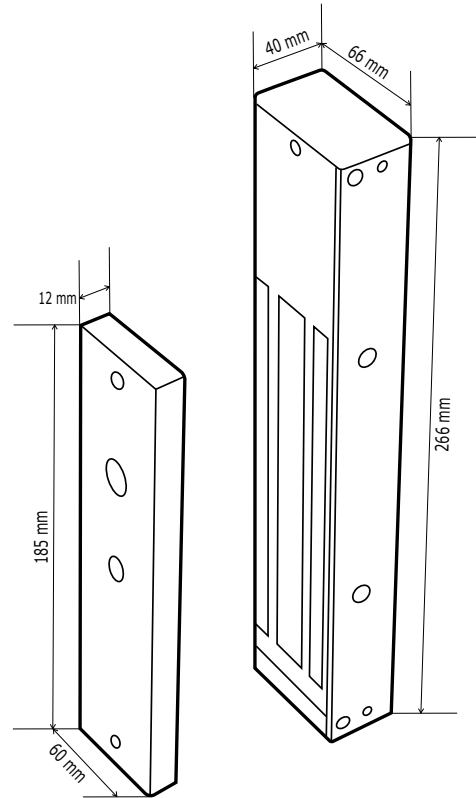

## Electrical Specifications

<b>Power input:</b>	12/24Vdc
<b>Consumption:</b>	480mA @ 12Vdc 240mA @ 24Vdc

## Accessories



**500-ZL**

ZL bracket for 500kg maglock



**DPM-500**

Door position monitor for 500kg surface maglock

## Range References

F0526000004	V5SR	Surface 500kg magnetic lock, monitored, fire rated
F0526000018	V5SR-B	Surface 500kg magnetic lock, monitored with buzzer