

Datasheet

ELECTRO-MAGNETIC LOCKS/ SD Series - Internal Double Surface Magnetic Lock

Product description

The SD Series are monitored surface maglocks with a holding force of up to 300kg ([SD300M](#)) or 500kg ([SD500M](#)) on each side.

The SD Series is part of CDVI's premium range, offering high quality and high performance locking with exceptional features to enhance your installation.

Each magnet is supplied in a professional packaging for ease of identification. Each package includes security "catch" ropes to prevent the magnetic lock from falling, ensuring the locks can be mounted safely without risk of injury.



Key features

- Double surface mount maglock
- Up to 300kg or 500kg holding force on each side
- Monitored
- CDVI Premium Range
- Designed with safety features

 *Certification*

 *DEEE*

 *Certification*

 *IP42*

Product Specifications

Holding force: 2 x 300 (SD300M)
or 2 x 500kg (SD500M)

Monitoring: lock status - COM, NO, NC

Electrical Specifications

Voltage: 12/24Vdc

Current: @12Vdc = 1.1mA (600mA per side),
@24Vdc = 550mA (300mA per side)

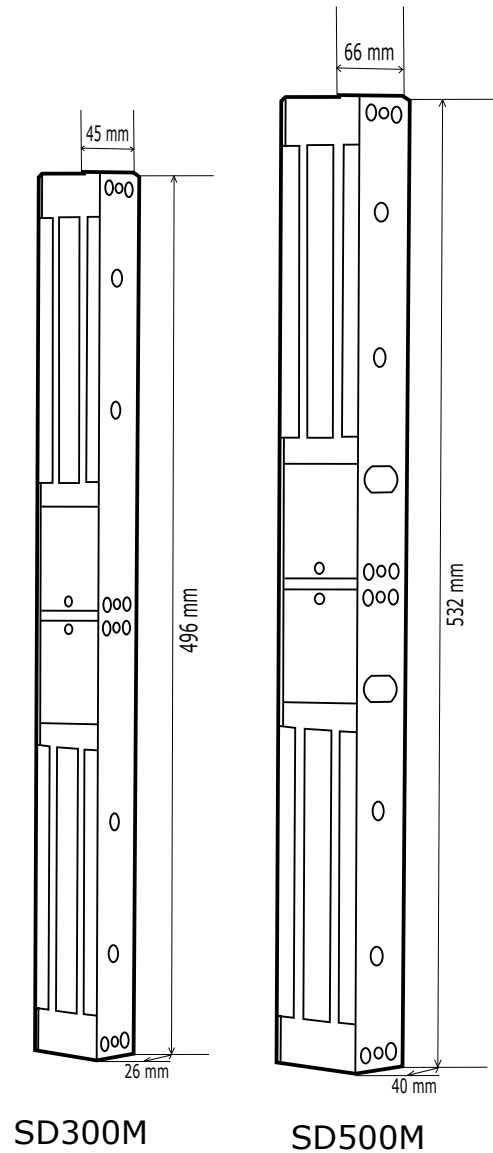

SD300M

SD500M