

# PHOTOELECTRIC BEAM SENSOR

## (Reflection type)

**PR-30BE** Outdoor 0.5 to 30m. (1.7 to 100ft.)  
Indoor 0.5 to 40m. (1.7 to 135ft.)



*The newly developed PR-30BE, adopting Time of flight technology, can protect 30m (outdoor) with one side wiring*

### EASY INSTALLATION

As wiring is needed only on the sensor unit (one side), you can use it in places where it is difficult to wire on both sides. One-side wiring reduces time and cost of installation significantly.

### MORE RELIABLE PROTECTION (Time of Flight)

Adopting ToF technology makes the detection more secure regardless of environment and material/color of the object, by avoiding lost alarms caused by wrap-around of the reflected beam near the center of the detection area.

### FOR INDOOR AND OUTDOOR APPLICATIONS

This sensor can be used both indoor and outdoor. Maximum detection distance can be 40m for indoor applications (hood of reflector is detachable).

### EASY BEAM ALIGNMENT

Beam alignment can be adjusted on the sensor unit side only by utilizing dual ring viewfinder, monitor output and new sound check function. (Intermittent and continuous tone)

### FLEXIBLE PROTECTION AREA SETTING

The lens is adjustable horizontally (+/-90 degrees) and vertically (+/-5 degrees) by thumbscrew without screw driver, allowing the unit to work in all directions.

### RESPONSE TIME ADJUSTMENT

Response time can be adjusted by DIP switch with 4 steps (0.05 / 0.1 / 0.25 / 0.5 sec.) to reduce false alarms depending on the location.

### MINIMUM OPERATIONAL DISTANCE

Even narrow zones can be protected with minimum operational detection distance of 0.5m, widening the area of applications.

### EASY OPERATION CHECK

Alarm LED (red), attenuation LED, and sound check are equipped for quick and easy operation check. (After closing the cover, the sensor will enter walk test mode for a period of 5 minutes. During this time, a sounder will activate upon detection. The walk test mode will automatically terminate after 5 minutes.)

### OPTION ACCESSORIES

L fitting (BL-11) is available as option to mount the reflector for protection along the wall.

# PHOTOELECTRIC BEAM SENSOR

## DETECTION AREA

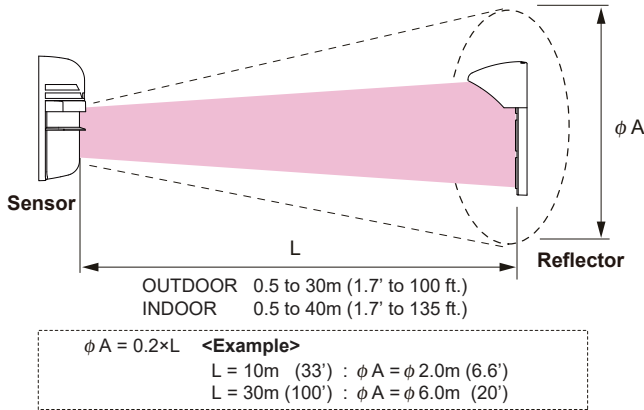

## EXTERNAL DIMENSIONS

Unit : mm (inch)

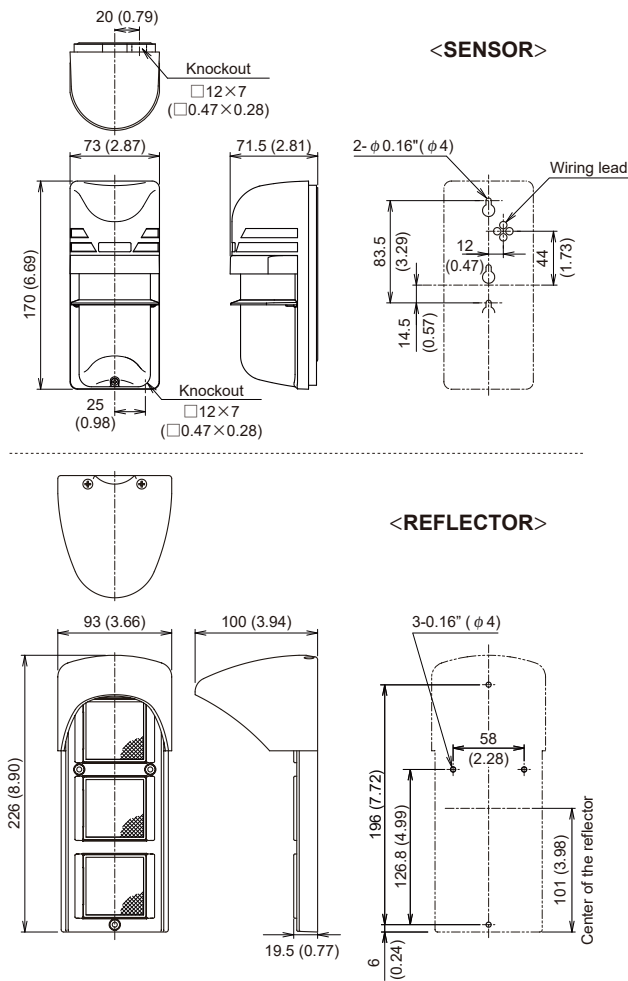

## OPTIONAL

- L fittings  
    <BL-11>



## TERMINAL CONFIGURATION

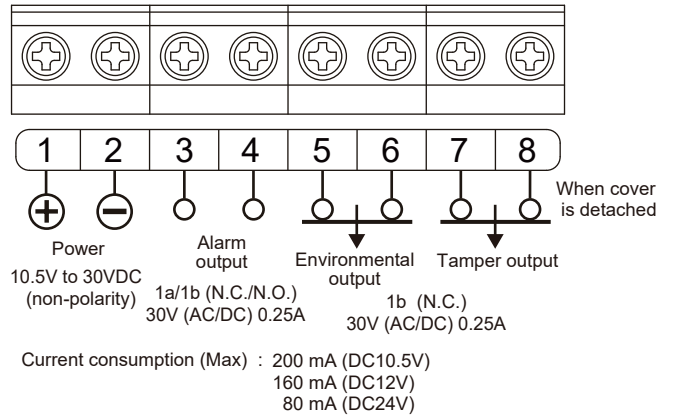

## Wiring distance

Wire size	Voltage	DC12V	DC24V
AWG 22 (Dia 0.65mm)		50m (165')	500m (1,650')
AWG 20 (Dia 0.8mm)		50m (165')	750m (2,500')
AWG 18 (Dia 1.0mm)		100m (330')	1,200m (4,000')
AWG 17 (Dia 1.1mm)		150m (500')	1,400m (4,600')

(Note) Maximum wiring distance, when two or more sets are connected, is the value above divided by the number of sets.

## SPECIFICATIONS

Model	PR-30BE
Detection system	Near infrared beam interruption system (reflective)
Protection distance	Outdoor 0.5 to 30m (1.7 to 100') Indoor 0.5 to 40m (1.7 to 135')
Supply voltage	10.5V to 30V DC (Non-polarity) (Class 2 powered device)
Current consumption	200 mA or less 160 mA or less (12V DC) 80 mA or less (24V DC)
Alarm output	Dry contact relay N.C. / N.O. Contact capacity : 30V (AC/DC) 0.25A or less Relay operation : Normal / Real time Normal : Interruption time (min. 2 secs) Real time : Interruption time
Environmental output	Dry contact relay N.C. Contact capacity : 30V (AC/DC) 0.25A or less
Tamper output	Dry contact relay N.C. Action : Activated when cover is detached. Contact capacity : 30V (AC/DC) 0.25A or less
Response time	0.05 / 0.1 / 0.25 / 0.5 sec.
Alarm LED	Red LED ON : when an alarm is initiated
Sensitivity attenuation / Environment LED	Red LED When front cover detached (when alignment) : Beam is attenuated. When front cover attached : Weather condition gets worse. (Synchronize with Env.output)
Functions	• Monitor output    • Response time adjustment
Ambient temperature range	-25°C to +60°C (-13°F to +140°F)
Mounting positions	Outdoor / Indoor
Wiring	Terminals
Weight	Sensor : 370g (13oz)    Reflector : 190g (6.7oz)
Appearance	Sensor : Resin (wine red) Reflector : Resin (clear / black)

\* Specifications and design are subject to change without prior notice.



### Please note:

This sensor is designed to detect intrusion and flame to initiate an alarm; it is not a burglary or a crime preventing device. TAKEX is not responsible for damage, injury or losses caused by accident, theft, Acts of God (including inductive surge by lightning), abuse, misuse, abnormal usage, faulty installation or improper maintenance.