



*Televes reserves the right to modify the product*

## Overlight optical transmitter DWDM, Indoor use, DAB/UHF/SAT, Ch33, Po 9dBm

Enhanced electronics and optical engineering to light up your TV

DWDM WideBand satellite and terrestrial optical transmitter specifically designed for indoor installation. Intended for four-satellite transmission solutions to up to more than 64 users with the use of amplification, this device receives a satellite signal from a RF Wideband LNB and terrestrial band, and distributes it over a fiber output in the Channel 33 (1550.92 nm) with 9dBm optical power.

Thanks to its optimized electronics and low losses, it allows reducing the number of amplifiers required and simplifies deployment in the design of collective installations, preserving the signal quality throughout the process. Furthermore, it is fully indicated for use in GPON installations and adapts to different solutions.

This device is part of the Overlight system, that distributes satellite and terrestrial signals to multiple users through a single optical fiber.

<b>Ref.</b>	237573
<b>Logical ref.</b>	OLTCH33K
<b>EAN13</b>	8424450315385

## Packaging info

---

<b>Box</b>	1 pcs.
------------	--------

---

## Physical data

---

<b>Net weight</b>	400.00 g
-------------------	----------

---

<b>Gross weight</b>	641.00 g
---------------------	----------

---

<b>Width</b>	137.00 mm
--------------	-----------

---

<b>Height</b>	123.00 mm
---------------	-----------

---

<b>Depth</b>	45.00 mm
--------------	----------

---

<b>Main product weight</b>	400.00 g
----------------------------	----------

---

## Highlights

---

- High output level that makes it ideal for collective installations
- Specially designed for use in 4-satellite transmission to up more than 64 users in combination with amplification modules
- DWDM based transmission (Dense Wavelength Division Multiplexing)
- ITU-T G.694.1 DWDM compliant
- Compatible with GPON/RFoG deployments
- Low losses
- Optimized electronic behavior
- Very compact in dimensions and weight
- Designed for indoor installation
- Powering from an external power supply, via power input (F connector)
- 100% European design, quality, and manufacturing
- SC/APC optical connector
- F-type RF connectors
- High-screening Zamak chassis
- Wall and mast mounting
- Power supply and adapter cable included
- LED signal status indicator

## Discover

---

### WideBand technology

WideBand (also known as FullBand) refers to broadband transmission technology that uses a wide range of frequencies. In WideBand TV systems, a substantial portion or the whole of the frequency spectrum is available to users. It can be used in fiber deployments where long cable runs are demanded, or coaxial scenarios in combination with multiswitches adapted to this technology.

In WideBand technology, an LNB captures a complete satellite signal and distributes it through 2 universal outputs (vertical -V- and horizontal -H-), each of them with the combination of high (H) and low (L) bands, in a frequency range between 290 and 2340 MHz.

**Despite the fact that Quattro technology is the most widely deployed technology in TV systems nowadays, WideBand technology brings significant advantages to the installation:**

- **Simpler, faster and cleaner installation:** In WideBand technology the number of coaxial cables connecting the LNB to the multiswitches is half as in traditional Quattro deployments, so the installation is done quicker and easier. The installation will also be tidier with fewer cables.
- **Wider bandwidth than other technologies:** WideBand channels can carry more information thanks to their wide bandwidth (290-2340 MHz). This powerful feature allows a greater number of services to be delivered to the end users of the installation.
- **Reusable deployment:** WideBand technology allows signal distribution by reusing a Quattro installation. It can be distributed through the old 4 cables coming down from the roof to capture signals from up to 2 satellites, changing only LNBs and MSWs to be WideBand compatible.

## Application example

---

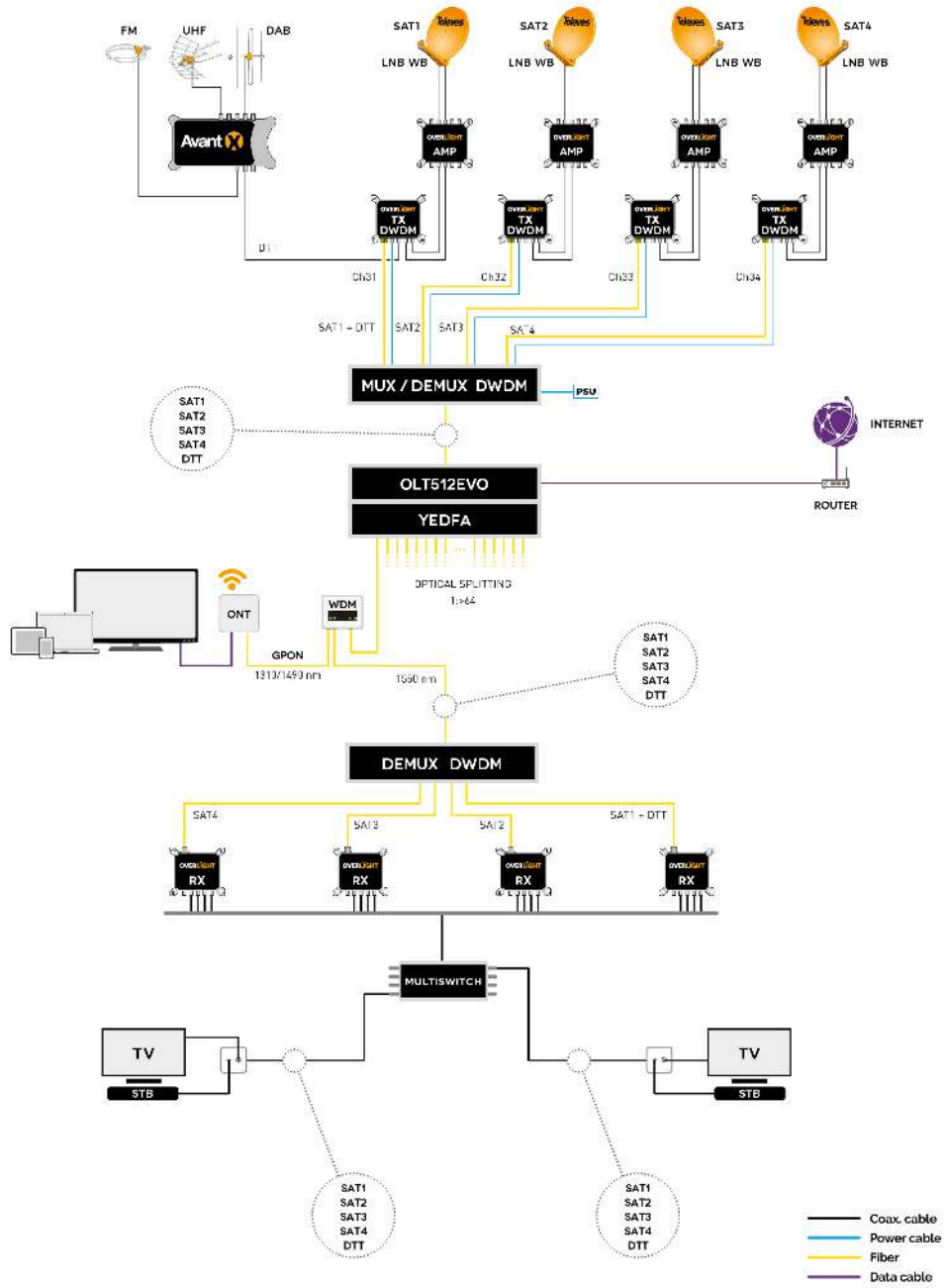

## Technical specifications : Ref. 237573

Inputs/Bands		TERR	V	H
Frequency range	MHz	47 ... 694	290 ... 2340	290 ... 2340
Input level	dBµV	83 ... 95	70 ... 85	70 ... 85
Number of MUX for Input level		25	52	52
MUX bandwidth for Input level	MHz	8	40	40
Powering per inputs	Vdc	11.7 ... 17.7	11.7 ... 17.7	--
Max. current pass	mA	500	500	--
Max. current pass total inputs	mA		720	
Impedance	Ω		75	
Laser			MQW-DFB cooled	
Wavelength	nm		1550.92	
Optical output power	dBm		9	
RF connectors			"F" female	
Optical connectors			SC/APC	
Powering	Vdc		12 ... 18	
Max. power consumption	W		5.88	
Current consumption	mA		< 490	
Operating temperature	°C		-5 ... 45	
PSU input voltage	Vac		100 ... 240	
Max PSU current input	mA		600	
PSU output voltage	Vdc		12	
Max PSU output current	A		1.5	